

E-LINE CR Mounting Instructions

Vertical Application

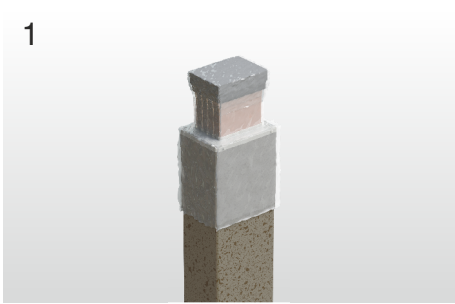

1 Stretch and head plastic at the tip of the busbar shall be removed.

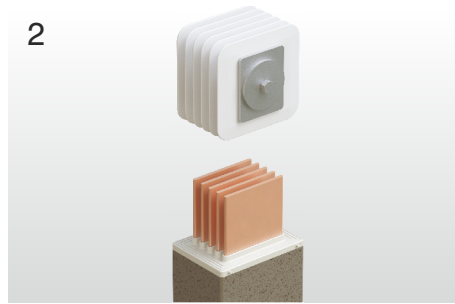

2 Tip parts exposed on the busbar are required to be cleaned with a clean and dry piece of cloth. After the completion of the cleaning process, it is aligned with the block joint tray and mounted on the stationary busbar. Block joint bolt shall be slightly tightened for not to falling.

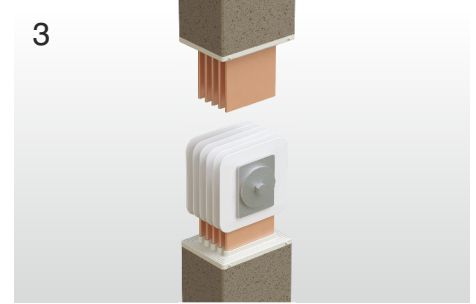

3 Second busbar is brought into alignment with the block joint. The block joint shall be loosened, and the second busbar shall be mounted on the stationary busbar. Bolt clearance is removed tightened slightly.

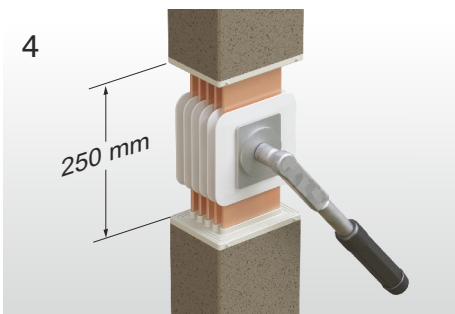

4 Coupled busbars and block joint shall be put into final form by looking at the alignments there of. Torqued with the torque wrench by setting to 83 Nm.

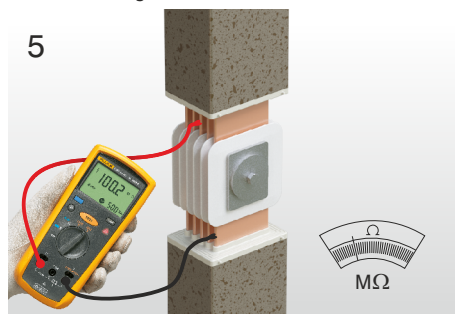

5 Megger test shall be conducted among the entire phases.

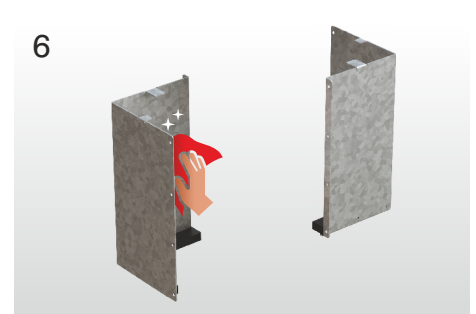

6 Inner surfaces of molds (surfaces subject to casting process) shall be cleaned with a clean and dry piece of cloth.

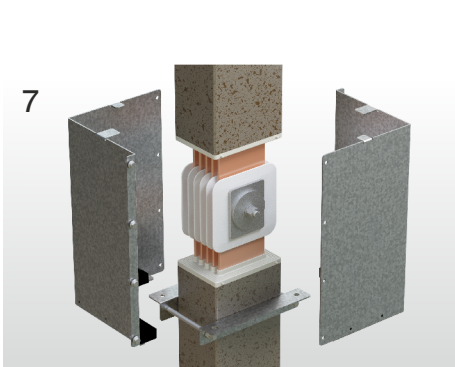

7 The support sheet delivered to assist that the block joint mold maintains its position shall be affixed. Block joint molds shall be brought on the support sheet and secured by means of bolts in a manner that the gaskets shall be at the bottom.

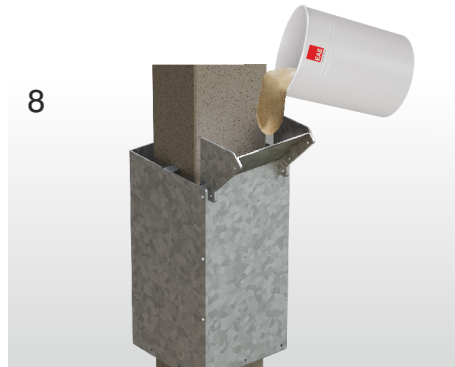

8 The alloy shall be casted uninterruptedly from the sheet that are delivered to assist the casting process from the same spot.

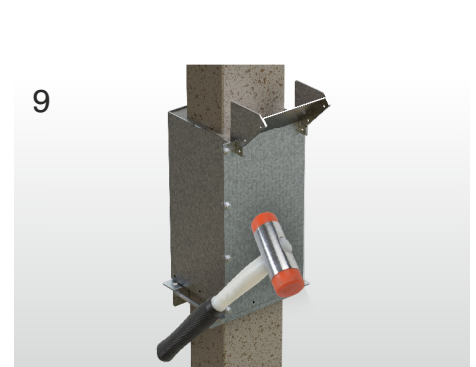

9 Vibration is provided by means of plastic hammer.

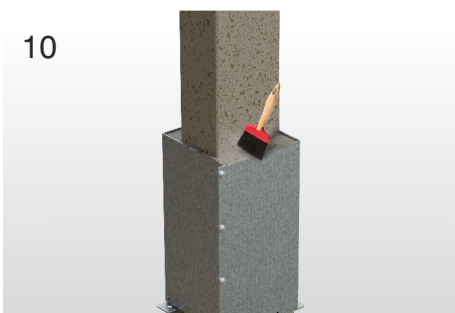

10 For each juncture, brushing for 2 minutes shall be performed once in every 10-15 minutes throughout 1 hour.

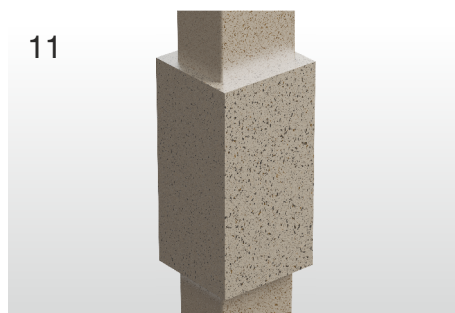

11 After the curing of the material (6-12 hours), casting mold shall be removed, and the sharpness of the part shall be smoothed accordingly. (Note: Varies depending on the seasonal conditions and temperature. Cold weather is disadvantageous.)



12 Megger test should not be conducted for a minimum of 12 hours after the casting process.

E-LINE CR Mounting Instructions

Resin Application



Megger test is definitely required to be conducted prior to the casting process.

Resin (A), Hardener (B) and fillers; must be stored at least one day over ($> 20^{\circ}\text{C}$).

Ambient temperature of job side must be $5^{\circ}\text{C} < T_{\text{amb}} < 40^{\circ}\text{C}$

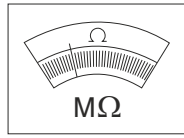

$\geq 1\text{M}\Omega$ OK
 $< 1\text{M}\Omega$ NOT OK

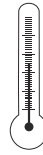

$< 5^{\circ}\text{C}$ → STOP
 $> 35^{\circ}\text{C}$ → STOP

$T(^{\circ}\text{C})$

Preparation of Cast Resin Mixture



FILLER



RESIN (A)



HARDENER (B)



1 Filler removed from the plastic bucket.

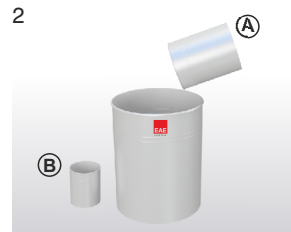

2 Resin and hardener are mixed in plastic bucket.

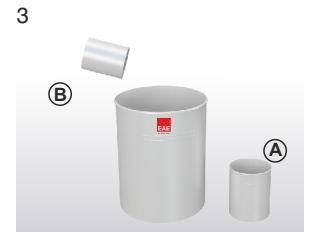

4 Mix resin and hardener thoroughly with stirrer at least 1 minute.



5 Add fillers and mix until homogeneous; at least 5 minutes. Then application must be done within 15 minutes.

Resin Application

After the entire adjustments are made, megger test and dielectric test shall be conducted on the busbar system coupled and absence of any stray voltage shall be ensured accordingly. Material prepared in buckets shall be casted on juncture area. Material casting shall be ensured not to have any clearance at all. After the completion of casting process, the material shall be ensured to be placed tightly by slightly hammering the block joint moulds.

- After the block joint mould is filled up to the upper level, the surface is required to be levelled out with a brush.
- For the purpose of expediting the air outlet after the completion of the casting process, vibration rendering process shall be applied on the mold for 8-10 minutes by a plastic hammer.
- Casting surface shall be brushed once in every 10-15 minutes and air bubbles forming shall be removed and the surface shall be smoothed accordingly.
- To remove the block joint mould, it shall be waited for curing process of 6-12 hours and the complete stiffening to be completed.

In case of a requirement of more than 1 dose of application in the application of the juncture resin, it shall be performed successively without waiting for the application of the 2nd and the 3rd doses.



Note: Material for each joint shall be prepared separately and this prepared material shall be poured within 15 minutes.